

AIR

1617

/

1010

JRLite
LIGHT FOR FUTURE

Index

P1

INTRODUCTION

What & Why & AIR
AIR FABE

P14-15

PACKAGE

Product Dimension
& Weight

P2-10

BASIC DATA

Product data
Electrical parameter
Accessories

P16-32

USER INSTRUCTION

Profile / Clips / Bracket

P11-13

WIRING

Single - End Wiring Diagram
Double - End Wiring Diagram



LIGHT FOR FUTURE



What is the AIR series?

True 3D Lighting — Redefining the Future of Form and Light

AIR Series represents JRLite's next-generation 3D flexible neon system — designed to deliver perfect curvature, seamless appearance, and unmatched luminous efficiency. From elegant architectural lines to complex curved installations, AIR achieves true 3D expression with precision, stability, and brilliance.

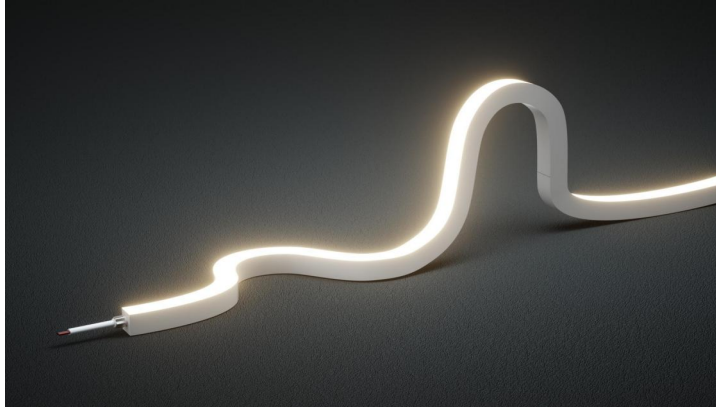

- True 3D form — No Roll Flat, No Stress Point
- High Efficacy 100 lm/W
- Premium DOW Material for superior UV and aging resistance
- Dual CCT option covering 2700K/3000K (SKU 4→1)
- Free Cut version — cut freely, light perfectly

AIR adapts to projects of all shapes and sizes — from architectural façades and retail, to hospitality and interior design spaces — delivering brilliance that matches your vision exactly.

Why is AIR series developed?

From Standard Bending to 3D Design — Lighting Needs Evolution

Traditional top-bend and side-bend neons lit spaces for years – but modern architecture needs more.

- Rigid bending and poor uniformity limit design freedom.
- Multiple SKUs increase workload and cost.

From 3D Innovation to 3D Limitations — Where Problems Appear

Even 3D neon still has issues.

- Stress points and roll flat lead to surface deformation and edge distortion.
- Low light efficiency creates uneven brightness and energy waste.



Conventional 3D:
Stress points



Conventional 3D:
Roll flat

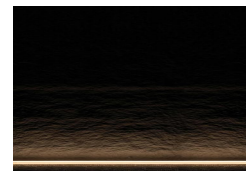

Conventional 3D:
Low Light Efficiency

From 3D Limits to True 3D Freedom — The AIR Solution

That's why we created AIR — True 3D Neon (Helix Neon).

With AIR, what you design is what you deliver — no roll flat, no stress point, no compromise.



Helix Neon AIR:
No Stress points



Helix Neon AIR:
No Stress points

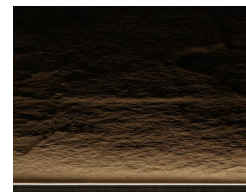

Helix Neon AIR:
High Efficacy 100 lm/W

LEDLINE AIR 1617

Shaping the Future of True 3D Neon



Advantages:

- LEDLINE AIR 1617, DC24V. Cross section size 16mm x 17mm / 0.63" x 0.67" (W x H), which is vertical bending and horizontal bending with diameter of 200mm/7.87".
- IP67 protection, UV resistance, and chemical resistance ensure the durability in various environments.
- Maximum 102LM/W efficacy reduces energy costs and heat while extending LED lifespan.
- 2-wire tunable white design combines 4 SKUs into one, reducing your inventory.
- True 3D bending with no stress points for cleaner installation - ideal for a wide range applications.

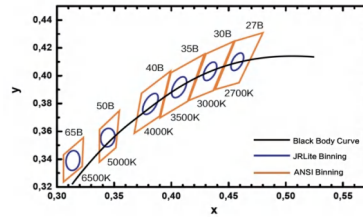

ONE BIN ONLY
 Color consistency
 Today and tomorrow

PRODUCT DATA

Product Name	LEDLINE AIR 1617
IP rated	IP67
Size	16*17mm(W*H)
Min. Bending Diameter	Top: 200mm; Side: 200mm
Bending Direction	3D Bending
Min. Cutting Length	62.5mm
Beam Angle	110°
Max. Production Length	20m
IK rated	IK10 (with AL profile, walk over only)

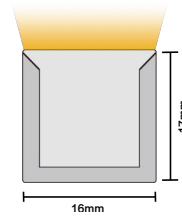

AIR16173D-24-930-100

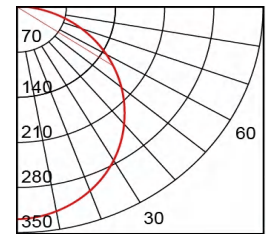

UNIT:cd
 -C90/270,114.5

ORDER CODE

SERIES NAME	BENDING DIR	VOLTAGE	RA CCT	WATTAGE	LENGTH	CABLE ENTRY
AIR 1617	3D	24=DC24V	922=RA90 2200K	100=10W/M	05000=5M	F=FRONT
			927=RA90 2700K			S=SIDE
			930=RA90 3000K			B=BOTTOM
			935=RA90 3500K			
			940=RA90 4000K			

SERIES NAME	BENDING DIR	VOLTAGE	RA CCT	WATTAGE	LENGTH	CABLE ENTRY
AIR 1617	3D	24=DC24V	9CS2730= RA90 2700K+3000K	100=10W/M	05000=5M	F=FRONT
						S=SIDE
						B=BOTTOM

ELECTRICAL PARAMETER

Data	AIR 1617 WHT	AIR 1617 CS
Power(W/m W/ft)	10/3.05	10/3.05
Voltage (V)	DC24V	DC24V
Current(mA/m)	416.67	416.67
Circuit Type	CV	CV
LED Type	2835	2835
Min. Cutting Length(mm)	62.5	62.5
Life Span L70B10	>44000H	>44000H
Storage Temp.	-40°C /-40° F _{min} 65°C /149° F _{max}	-40°C /-40° F _{min} 65°C /149° F _{max}
Ambient Temp. *	-40°C /-40° F _{min} 65°C /149° F _{max}	-40°C /-40° F _{min} 65°C /149° F _{max}











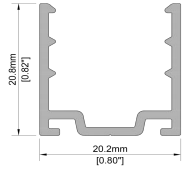

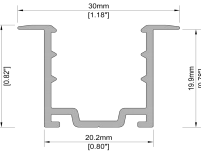

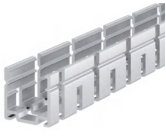
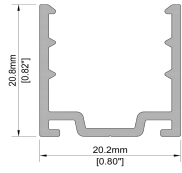



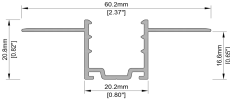

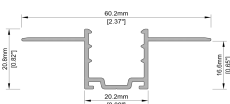



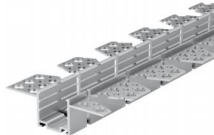
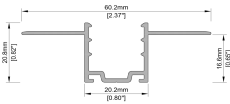

* Exceeding the maximum ratings will reduce expected life time or destory the LED strip.

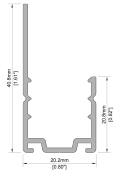
OPTICAL PARAMETER

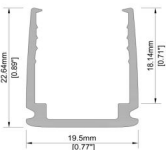
Item Code	Finished Product					LED	
	Wattage/m	CCT	CRI	Lumen/m	Lumen/ft	Color Tolerance	BIn
AIR16173D-24-922-100	10W	2200K	Ra≥90	860LM	262LM	<3SDCM	OneBinOnly
AIR16173D-24-927-100	10W	2700K	Ra≥90	970LM	296LM	<3SDCM	OneBinOnly
AIR16173D-24-930-100	10W	3000K	Ra≥90	1010LM	308LM	<3SDCM	OneBinOnly
AIR16173D-24-935-100	10W	3500K	Ra≥90	1040LM	317LM	<3SDCM	OneBinOnly
AIR16173D-24-940-100	10W	4000K	Ra≥90	1040LM	317LM	<3SDCM	OneBinOnly
AIR16173D-24-9CS2730-100	10W	2700K	Ra≥90	920LM	280LM	<3SDCM	OneBinOnly
AIR16173D-24-9CS2730-100	10W	3000K	Ra≥90	960LM	293LM	<3SDCM	OneBinOnly
AIR16173D-24-9CS2730-100	10W	2700+3000K	Ra≥90	930LM	284LM	<3SDCM	OneBinOnly

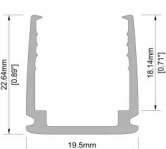
OPTIONAL ACCESSORIES

Profiles

			<p>Order Code AC167-AP</p> <p>Dimension 1000x20.2x20.8mm/ 39.37"x0.80"x0.82"(LxWxH)</p> <p>Material Aluminium</p> <p>Color Silver</p> <p>1mtr/pcs aluminium profile for surface application</p>
			<p>Order Code AC167-EP</p> <p>Dimension 1000x20.2x19.9mm/ 39.37"x0.80"x0.78"(LxWxH)</p> <p>Material Aluminium</p> <p>Color Silver</p> <p>1mtr/pcs aluminium profile for embedded application</p>
		  	<p>Order Code AC167-CR</p> <p>Dimension 1000x20.2x20.8mm/ 39.37"x0.80"x0.82"(LxWxH)</p> <p>Material Aluminium</p> <p>Color Silver</p> <p>1mtr/pcs curved aluminium profile for surface application Min. diameter for top/side bending: 600 mm</p>
			<p>Order Code AC167-LP</p> <p>Dimension 1000x20.2x16.6mm/ 39.37"x0.80"x0.65"(LxWxH)</p> <p>Material Aluminium</p> <p>Color Silver</p> <p>1mtr/pcs lace aluminium profile for embedded application</p>
		  	<p>Order Code AC167-CRL</p> <p>Dimension 1000x20.2x16.6mm/ 39.37"x0.80"x0.65"(LxWxH)</p> <p>Material Aluminium</p> <p>Color Silver</p> <p>1mtr/pcs lace aluminium profile for embedded application Min. diameter for top bending: 600mm; Side bending: 1600 mm</p>
		  	<p>Order Code AC167-SCRL</p> <p>Dimension 1000x20.2x16.6mm/ 39.37"x0.80"x0.65"(LxWxH)</p> <p>Material Aluminium</p> <p>Color Silver</p> <p>1mtr/pcs lace aluminium profile for embedded application Min. diameter for top/side bending: 600 mm</p>
			<p>Order Code AC167-BA</p> <p>Dimension 1000x20.2x40.8mm/ 39.37"x0.80"x1.61"(LxWxH)</p> <p>Material Aluminium</p> <p>Color Silver</p> <p>1mtr/pcs anti glare baffle profile for surface application</p>
			<p>Order Code AC167-PC</p> <p>Dimension 1000x19.5x22.64mm/ 39.37"x0.8"x0.65"(LxWxH)</p> <p>Material PVC</p> <p>Color Transparent</p> <p>1mtr/pcs curved PC profile for surface application</p>
		  	<p>Order Code AC167-CPC</p> <p>Dimension 1000x19.5x22.64mm/ 39.37"x0.8"x0.65"(LxWxH)</p> <p>Material PVC</p> <p>Color Transparent</p> <p>1mtr/pcs curved PC profile for surface application Min. diameter for top/side bending: 300 mm</p>

OPTIONAL ACCESSORIES

Profiles

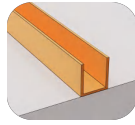
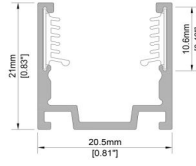

Order Code	AC167-SGP
Dimension	1000x20.5x21mm/ 39.37"x0.81"x0.83"(LxWxH)
Material	Aluminium with silicone grooved
Color	Silver
1mtr/pcs aluminium profile for surface application	

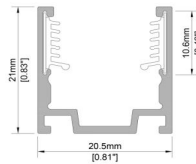

Order Code	AC167-CSGP
Dimension	1000x20.5x21mm/ 39.37"x0.81"x0.83"(LxWxH)
Material	Aluminium with silicone grooved
Color	Silver
1mtr/pcs cruved profile for surface application(Only Side Bend)	

Profile Bracket

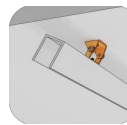
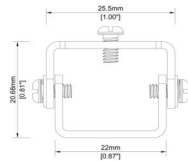

Order Code	AC167-AMB
Dimension	25.5x15x20.68mm/ 1"x0.59"x0.81"(LxWxH)
Material	Stainless steel
Color	Silver
1 pcs profile angle mounting bracket + 1 screw	

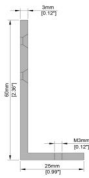

Order Code	AC167-SET-LA
Dimension	20x25x60mm/ 0.79"x0.99"x2.36"(LxWxH)
Material	Aluminium
Color	Silver
1 pcs L shape profile bracket + 3 screw	

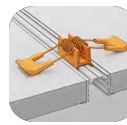
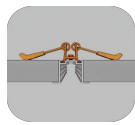
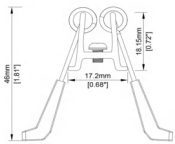

Order Code	AC167-SET-LC
Dimension	30x17.2x18.15mm/ 1.18"x0.68"x0.71"(LxWxH)
Material	Aluminium
Color	Silver & orange
Lifting Clip for Embedded Profile	

Clips

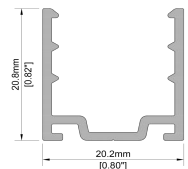

Order Code	AC167-MC
Dimension	25x20.2x20.8mm/ 0.98"x0.80"x0.82"(LxWxH)
Material	Aluminium
Color	Silver
Each meter led strip needs 4 clips + 4 screws	

Tool

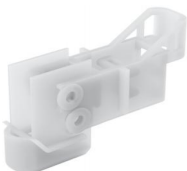

Order Code	IF-167
Material	PC
Color	White
Insertion Fixture for ACE 1617(only for curved PC profile)	

OPTIONAL ACCESSORIES

Cable Entry

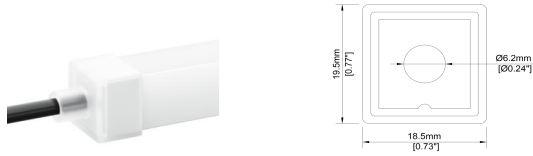

Order Code	AC167-EC2-F
Dimension	13x18.5x19.5mm/ 0.52"x0.73"x0.77"(LxWxH)
Material	Silicone
Color	Opal
1pcs cap+30cm Black PVC cable (Front Cable Entry)	

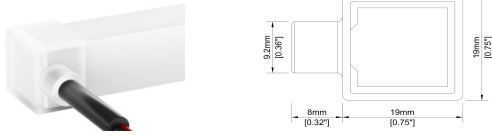

Order Code	AC167-EC2-S
Dimension	14x19x19mm/ 0.55"x0.75"x0.75"(LxWxH)
Material	Silicone
Color	Opal
1pcs cap+30cm Black PVC cable (Side Cable Entry)	

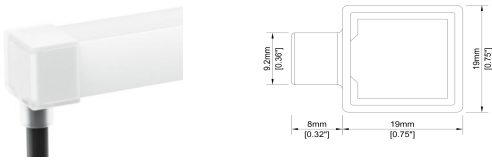

Order Code	AC167-EC2-B
Dimension	14x19x19mm/ 0.55"x0.75"x0.75"(LxWxH)
Material	Silicone
Color	Opal
1pcs cap+30cm Black PVC cable (Bottom Cable Entry)	

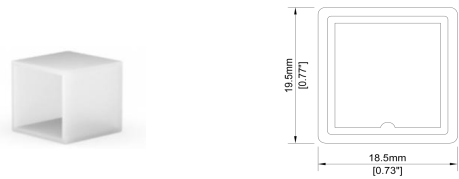

Order Code	AC167-EC
Dimension	14x19x19mm/ 0.55"x0.75"x0.75"(LxWxH)
Material	Silicone
Color	Opal
1pcs closed endcap	

Connector



Order Code	AD007A-2
Wire Gauge	0.519mm ² /20AWG
Protection	IP67 (Mated)
Material	PVC
Color	Black/White
1 pair of IP67 Connector 2PIN	

LEDLINE AIR 1010

Shaping the Future of True 3D Neon



Advantages:

- LEDLINE AIR 1010, DC24V. Cross section size 10mm x 10mm / 0.39" x 0.39" (W x H).
- Innovative free bending design accommodates both vertical bending and horizontal bending with diameter of 200mm / 7.87"
- IP67 protection, UV resistance, and chemical resistance ensure the durability in various environments.
- Equipped with a 3-Step MacAdam LED bin and dot free lighting technology.
- 2-wire tunable white design combines 4 SKUs into one, reducing your inventory.
- True 3D bending with no stress points for cleaner installation - ideal for a wide range applications.

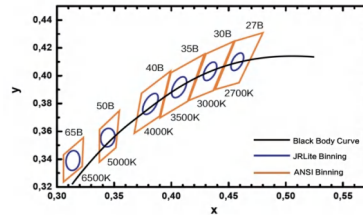

ONE BIN ONLY
 Color consistency
 Today and tomorrow

PRODUCT DATA

Product Name	LEDLINE AIR 1010
IP rated	IP67
Size	10*10mm(W*H)
Min. Bending Diameter	Top: 200mm; Side: 200mm
Bending Direction	3D Bending
Min. Cutting Length	41.67mm
Beam Angle	110°
Max. Production Length	20m

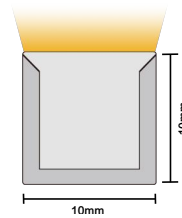

AIR10103D-24-930-100

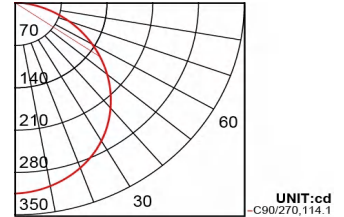

ORDER CODE

SERIES NAME	BENDING DIR	VOLTAGE	RA CCT	WATTAGE	LENGTH	CABLE ENTRY
AIR 1010	3D	24=DC24V	922=RA90 2200K	100=10W/M	05000=5M	F=FRONT
			927=RA90 2700K			S=SIDE
			930=RA90 3000K			B=BOTTOM
			935=RA90 3500K			
			940=RA90 4000K			

SERIES NAME	BENDING DIR	VOLTAGE	RA CCT	WATTAGE	LENGTH	CABLE ENTRY
AIR 1010	3D	24=DC24V	9CS2730=	100=10W/M	05000=5M	F=FRONT
			RA90 2700K+3000K			S=SIDE
						B=BOTTOM

ELECTRICAL PARAMETER

Data	AIR 1010 WHT	AIR 1010 CS
Power(W/m W/ft)	10/3.05	10/3.05
Voltage (V)	DC24V	DC24V
Current(mA/m)	416.67	416.67
Circuit Type	CV	CV
LED Type	2835	2835
Min. Cutting Length(mm)	41.67	41.67
Life Span L70B10	>44000H	>44000H
Storage Tempt.	-40°C /-40° F _{min} 65°C /149° F _{max}	-40°C /-40° F _{min} 65°C /149° F _{max}
Ambient Tempt. *	-40°C /-40° F _{min} 65°C /149° F _{max}	-40°C /-40° F _{min} 65°C /149° F _{max}



* Exceeding the maximum ratings will reduce expected life time or destory the LED strip.

OPTICAL PARAMETER



Item Code	Finished Product					LED	
	Wattage/m	CCT	CRI	Lumen/m	Lumen/ft	Color Tolerance	BIn
AIR10103D-24-922-100	10W	2200K	Ra≥90	790LM	241LM	<3SDCM	OneBinOnly
AIR10103D-24-927-100	10W	2700K	Ra≥90	890LM	271LM	<3SDCM	OneBinOnly
AIR10103D-24-930-100	10W	3000K	Ra≥90	930LM	284LM	<3SDCM	OneBinOnly
AIR10103D-24-935-100	10W	3500K	Ra≥90	950LM	290LM	<3SDCM	OneBinOnly
AIR10103D-24-940-100	10W	4000K	Ra≥90	950LM	290LM	<3SDCM	OneBinOnly
AIR10103D-24-9CS2730-100	10W	2700K	Ra≥90	780LM	238LM	<3SDCM	OneBinOnly
AIR10103D-24-9CS2730-100	10W	3000K	Ra≥90	810LM	247LM	<3SDCM	OneBinOnly
AIR10103D-24-9CS2730-100	10W	2700+3000K	Ra≥90	800LM	244LM	<3SDCM	OneBinOnly



OPTIONAL ACCESSORIES

Profiles

			Order Code AC023-AP Dimension 1000x12.4x12.9mm/ 39.37"x0.49"x0.51"(LxWxH) Material Aluminium Color Silver 1mtr/pcs aluminium profile for surface application
--	--	---	---

			Order Code AC023-PCU Dimension 1000x12.9x14.42mm/ 39.37"x0.51"x0.57"(LxWxH) Material PC Color Transparent 1mtr/pcs PC profile for surface application
--	--	---	--

			Order Code AC023-CPCU Dimension 1000x12.9x14.42mm/ 39.37"x0.51"x0.57"(LxWxH) Material PC Color Transparent 1mtr/pcs curved PC profile for surface application
--	--	---	--

			Order Code AC023-CR Dimension 500x10.9x10.1mm/ 19.69"x0.43"x0.41"(LxWxH) Material Stainless steel Color Silver 1mtr/pcs curved profile for surface application
---	--	---	---

			Order Code AC023-LP Dimension 1000x13.4x11.3mm/ 39.37"x0.53"x0.45"(LxWxH) Material Aluminium Color Silver 1mtr/pcs lace aluminium profile for embedded application
--	--	---	---

			Order Code AC023-SP Dimension 1000x16.1x80mm/ 39.37"x0.63"x3.15"(LxWxH) Material Aluminium Color Silver 1mtr/pcs skirting profile
--	--	---	--

			Order Code AC023-OCPU Dimension 1000x50.43x22.28mm/ 39.37"x1.99"x0.88"(LxWxH) Material Aluminium Color Silver 1mtr/pcs outside corner profile
--	--	---	--

			Order Code AC167-PC Dimension 1000x19.5x22.64mm/ 39.37"x0.8"x0.65"(LxWxH) Material PVC Color Transparent 1mtr/pcs inside corner profile
--	--	---	--

Profiles

	Order Code AD0M8A-2 Wire Gauge 0.519mm ² /20AWG Protection IP67 (Mated) Material PVC Color Black/White 1 pair of IP67 Connector 2PIN
--	---

OPTIONAL ACCESSORIES

Profile Bracket

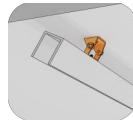
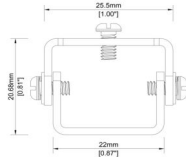

Order Code	AC167-AMB
Dimension	25.5x15x20.68mm/ 1"x0.59"x0.81"(LxWxH)
Material	Stainless steel
Color	Silver
1 pcs profile angle mounting bracket + 1 screw	

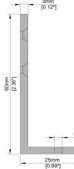

Order Code	AC167-SET-LA
Dimension	20x25x60mm/ 0.79"x0.99"x2.36"(LxWxH)
Material	Aluminium
Color	Silver
1 pcs L shape profile bracket + 3 screw	

Clips

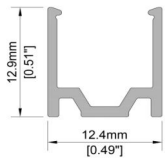

Order Code	AC025-MC
Dimension	25x12.4x12.9mm/ 0.98"x0.49"x0.51"(LxWxH)
Material	Aluminium
Color	Silver
Each meter led strip needs 4 clips + 4 screws	

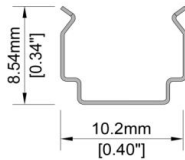

Order Code	AC025-SET
Dimension	10.5x7x8.5mm/ 0.41"x0.27"x0.33"(LxWxH)
Material	Stainless steel
Color	Silver
Each meter led strip needs 4 clips + 4 screws	

Cable Entry

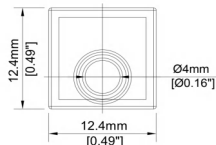

Order Code	AD025-2-F
Dimension	19x12.4x12.4mm/ 0.75"x0.49"x0.49"(LxWxH)
Material	Silicone
Color	Opal
1pcs cap+30cm Black PVC cable (Front Cable Entry)	

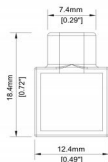

Order Code	AD025-2-S
Dimension	14.5x12.4x18.4mm/ 0.57"x0.49"x0.72"(LxWxH)
Material	Silicone
Color	Opal
1pcs cap+30cm Black PVC cable (Side Cable Entry)	

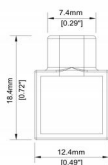

Order Code	AD025-2-B
Dimension	14.5x12.4x18.4mm/ 0.57"x0.49"x0.72"(LxWxH)
Material	Silicone
Color	Opal
1pcs cap+30cm Black PVC cable (Bottom Cable Entry)	

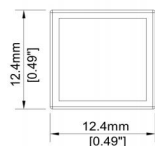

Order Code	AD025
Dimension	12x12.4x12.4mm/ 0.47"x0.49"x0.49"(LxWxH)
Material	Silicone
Color	Opal
1pcs closed endcap	

Single – End Wiring Diagram

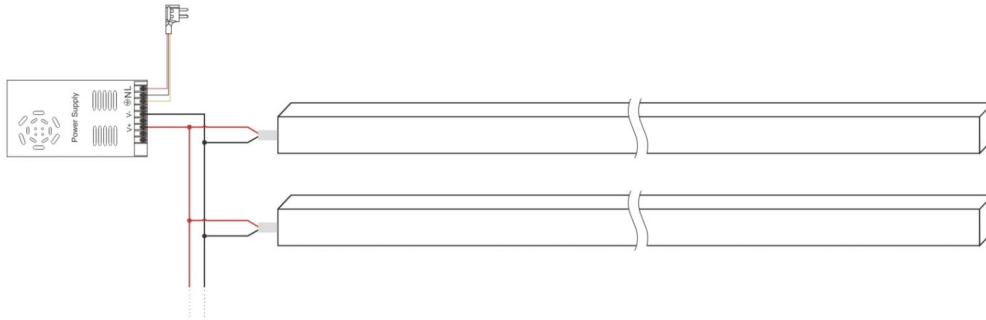

1. Our constant voltage and constant current just means the circuit design, all JRLite neon flex and led strip use constant voltage drivers.
2. Utilize a constant voltage power supply with appropriate output voltage. The rated wattage of the power supply should be 20% higher than the actual power consumption of the neon flex and led strip to extend its lifespan.
3. Dimming frequency is from 100Hz to 2000Hz. 500Hz is recommended.



- Please ensure the cable length is not more than the table "Max. Cable Length" according to LED strip length and its wire gauge.
- Please ensure the LED strip length is less than the table "Max. Strip Length".

Max. Strip Length_Single –end feed in Cable Entry Type



Type	Cable Gauge	Integrated cable entry	Silicone cable entry
IP Rating	/	IP67	IP67
AIR 1617 WHT – 10W	30cm 20AWG*2	5m/16.4ft	5m/16.4ft
AIR 1617 CS – 10W	30cm 20AWG*2	5m/16.4ft	5m/16.4ft
AIR 1010 WHT – 10W	30cm 20AWG*2	5m/16.4ft	5m/16.4ft
AIR 1010 CS – 10W	30cm 20AWG*2	5m/16.4ft	5m/16.4ft

Double – End Wiring Diagram

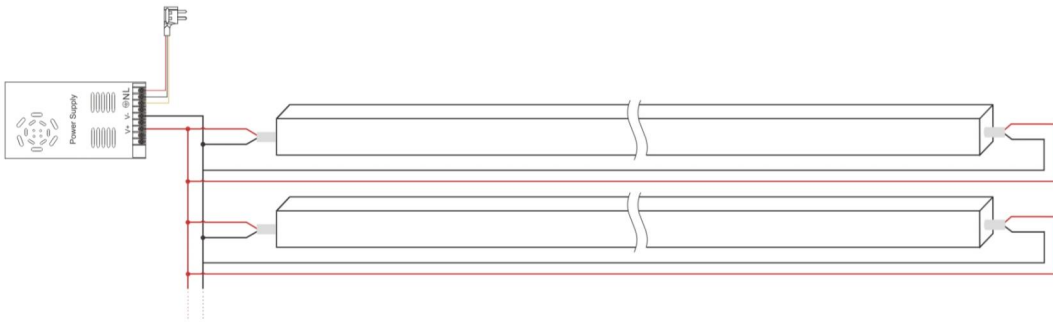

1. Our constant voltage and constant current just means the circuit design, all JRLite neon flex and led strip use constant voltage drivers.
2. Utilize a constant voltage power supply with appropriate output voltage. The rated wattage of the power supply should be 20% higher than the actual power consumption of the neon flex and led strip to extend its lifespan.
3. Dimming frequency is from 100Hz to 2000Hz. 500Hz is recommended.
4. When double ended power supply is used, it should be connected to the same driver and cannot be connected to two power driver.



- Please ensure the cable length is not more than the table "Max. Cable Length" according to LED strip length and its wire gauge.
- Please ensure the LED strip length is less than the table "Max. Strip Length".

Max. Strip Length_Double –end feed in Cable Entry Type



Type	Cable Gauge	Integrated cable entry	Silicone cable entry
IP Rating	/	IP67	IP67
AIR 1617 WHT – 10W	30cm 20AWG*2	8m/26.2ft	8m/26.2ft
AIR 1617 CS – 10W	30cm 20AWG*2	8m/26.2ft	8m/26.2ft
AIR 1010 WHT – 10W	30cm 20AWG*2	8m/26.2ft	8m/26.2ft
AIR 1010 CS – 10W	30cm 20AWG*2	8m/26.2ft	8m/26.2ft

RELIABILITY TEST

Test Item	Test Purpose
High – low temperature test	By simulating product operation in high – and low – temperature environments, detect performance, reliability and normal – working ability under extreme temperatures.
Waterproof test	Detect product's water – proof ability to see if it can prevent water entry during different water contacts without affecting function or causing damage.
Temperature rise test	Test product – temperature rises during normal operation or specific loads to evaluate heat dissipation and thermal stability, ensuring no malfunction or performance drop from overheating.
Salt – spray test	Expose product to salt – spray to test corrosion resistance and evaluate durability and reliability in salty environments (e.g., seaside or chemically corrosive industrial areas).
Torsion test	detect its structural integrity (connection stability, enclosure and encapsulation integrity), optical performance (uniformity of light emission, brightness stability) and electrical performance (circuit conductivity, electrical insulation).
Voltage drop test	Measure the voltage drop of the circuit/component to determine that the power loss during the current – passing process meets the requirements.
Reverse polarity test	Detect its structural integrity (connection and enclosure/encapsulation), optical performance (light emission and brightness) and electrical performance (circuit and insulation).
Thermal shock test	Simulate rapid short – term temperature changes, test performance, reliability, material/structure stability under thermal shocks, determine adaptability to rapid temperature changes.
IK test	Executive standard: IEC 60068 –2 –75:2014; Test three points per meter and conduct three hammer tests on each point to ensure that the LED strip is normal.
UV test	To test UV – resistance and evaluate appearance/performance/material durability changes under long – term sunlight/UV exposure.
UL	To assess product safety, ensuring that products meet relevant US safety standards and safeguarding users and the environment.
TUV	Examines products in terms of safety, quality and environment to prove that the products meet relevant German and European standard requirements.
RoHS / REACH	Ensure compliance with hazardous substance restrictions in electronic products (RoHS) and safeguard human health and the environment through comprehensive chemical substance management (REACH), respectively.
CE	To determine that products comply with relevant EU directive requirements, so as to be freely circulated in the EU market and ensure that products meet standards in terms of health, safety and environmental protection.
CB	To obtain certifications and approvals from multiple countries through one – time testing, promoting the mutual recognition of products in international trade and reducing duplicate testing.
EPD	To provide a standardized and transparent assessment of a product's environmental impact throughout its lifecycle, enabling informed decisions for sustainability and compliance.

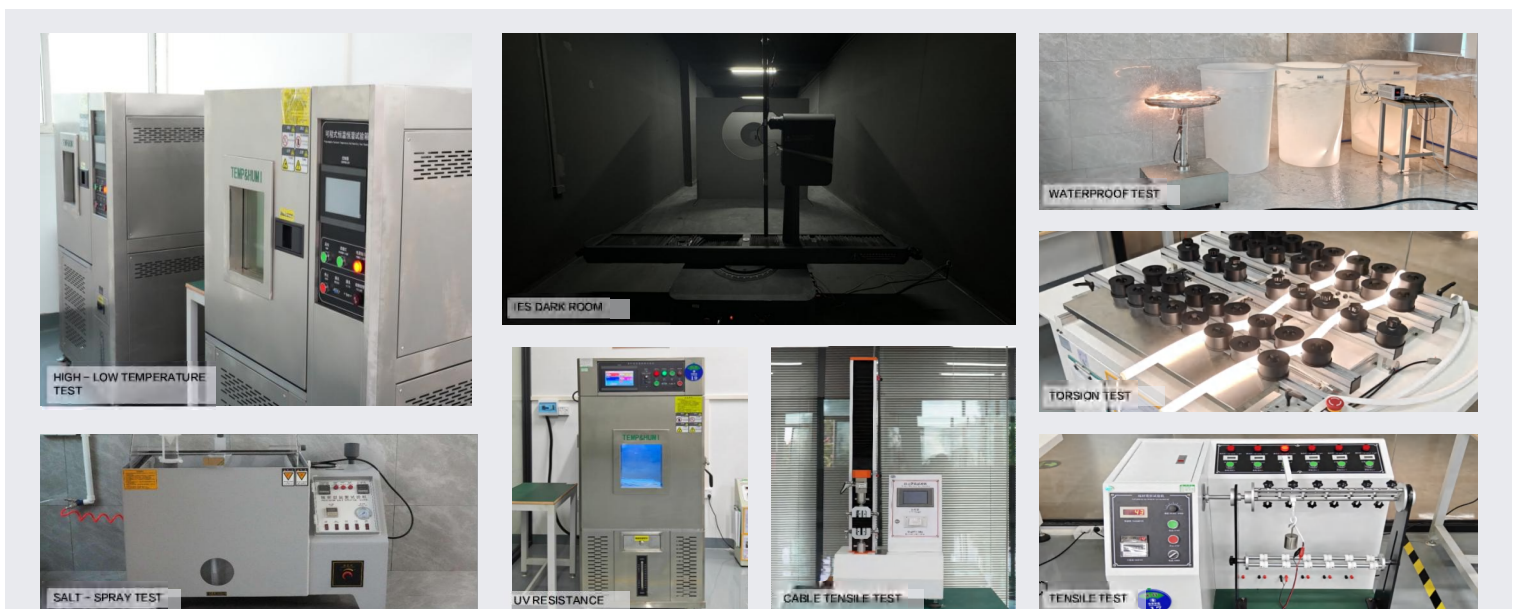

PRODUCT DIMENSION & WEIGHT

Item Code	Single Product				Package Info					
	L	W	H	Net weight	Packaging unit (Pieces/carton)	L	W	H	Volume	Gross weight
AIR 1617	1000mm	\	\	290.00g	/	/	/	/	/	/
AIR 1617	5000mm	\	\	1450.00g	12	400mm	400mm	310mm	49.60dm ³	20625.00g
AIR 1617	10000mm	\	\	2900.00g	5	400mm	400mm	310mm	49.60dm ³	17550.00g
AIR 1617	20000mm	\	\	5800.00g	3	400mm	400mm	310mm	49.60dm ³	19690.00g

*This table data is for reference only. Please refer to the actual shipment data of the product for accuracy.

Item Code	Single Product				Package Info					
	L	W	H	Net weight	Packaging unit (Pieces/carton)	L	W	H	Volume	Gross weight
AIR 1010	1000mm	\	\	125.00g	/	/	/	/	/	/
AIR 1010	5000mm	\	\	625.00g	12	400mm	400mm	310mm	49.60dm ³	10720.00g
AIR 1010	10000mm	\	\	1250.00g	5	400mm	400mm	310mm	49.60dm ³	9300.00g
AIR 1010	20000mm	\	\	2500.00g	5	400mm	400mm	310mm	49.60dm ³	15550.00g

*This table data is for reference only. Please refer to the actual shipment data of the product for accuracy.



ADDITIONAL PRODUCT INFORMATION

► **Equipped with accessories:** For ASTON and ACE series, they need to be equipped with profiles or other necessary equipment accessories.

► **IPC 6013C:** LED strips are designed for static installations in accordance with IPC 6013C - Use A. Take material vibrations, repetitive torsion, and elongation/compression into account.

► **Operating environment:** If the operating environment covers a broad temperature range (such as outdoors applications) and the operating length is longer than 2 meters, the use of adequate mounting surfaces is required. Assure enough space for strip expansion and heat dissipation with increasing temperature.

► **Power control and supply:** Use only SELV LED drivers in accordance with applicable lighting standards and LED strip ratings. In order to safely operate JRLITE LED strips it is necessary to supply them with an electronically stabilized power supply providing protection against short circuits, overload and overheating. Please select a power control device that meets international certification requirements to ensure the installation and operation of the product.

► **Hydrogen sulfide:** The manufacturer is not responsible for damage due to chemical corrosion. The user must provide suitable protection against corrosive agents such as moisture and condensation and any other harmful elements/compounds. Make certain to avoid corrosive atmospheres. According to the current state of LED technology, hydrogen sulfide (H₂S) causes accelerated corrosion which leads to shortened lifetime or premature failure. Sources of H₂S may be rubber, foam rubber, soft-foam tapes, rubber-based sealing, natural sources (e.g. sulfur springs), etc. To avoid H₂S from sulfur-vulcanized rubber use silicon-based materials or peroxide-crosslinked rubber instead. Follow the recommendations in the material datasheet of the rubber supplier.

► **Humidity and dust:** For applications involving exposure to humidity and dust, the strip must be protected by a fixture or housing with a suitable IP protection class.

► **Electrical isolation:** Always ensure electrical isolation between the LED strip and the mounting surface, especially in the vicinity of connections or cut ends.

► **Lifetime:** Exceeding maximum operating and storage temperature ratings can reduce the expected lifetime or even destroy the LED strip. The temperature of the LED strip must be measured at the T_c-point in accordance with EN 60598-1 under steady-state conditions, considering the worst case; drive all channels at 100 % power. Refer to the product drawing for the exact location of the T_c-point.

► **Installation:** Installation of LED strips and connection to the power supply must comply with all applicable electrical and safety standards.

Observe correct polarity and wiring diagrams! Incorrect polarity or wrong wiring can cause unpredictable permanent damage or even failure of the product.

Only a qualified electrician may install the strip.

Handle with care and ensure that there is no physical product damage, including damage to invisible internal electronics parts.

Exceeding the maximum ratings for the operating voltage causes hazardous overload and will likely destroy the LED strip.

Never exceed the maximum operable length, including other wires.

► **IP20 Product:** Part IP20 LED strips are equipped with a self-adhesive tape for attaching the LED strip to suitable materials, such as aluminum profiles, which must be clean and free of oil, silicone coatings, or any other dirt/dust particles. The adhesive tape is intended for single use, and if removed may damage the material to which it is stuck and the LED strip itself, which must then be scrapped. After products are equipped, it will take at least 72 hours to complete adhesion.

IP20 LED strips, as manufactured, have no conformal coating and therefore offer no inherent protection against corrosion. Conformal coating treatment (equipped with aluminum profiles) is possible, however materials must be selected properly in order to avoid product damage or impaired performance. The user must also completely seal the cut parts (ends/edges), to ensure the IP level still meet customer requirements.

IP20 LED strips are ESD-sensitive; take adequate precautions during installation and operation of the products.

► Consult JRLITE Technical Service for further advice.

USER INSTRUCTION

LEDLINE ACE 1617T

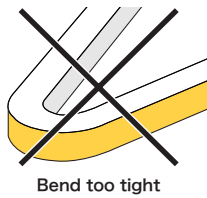
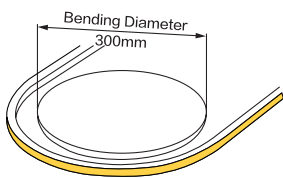
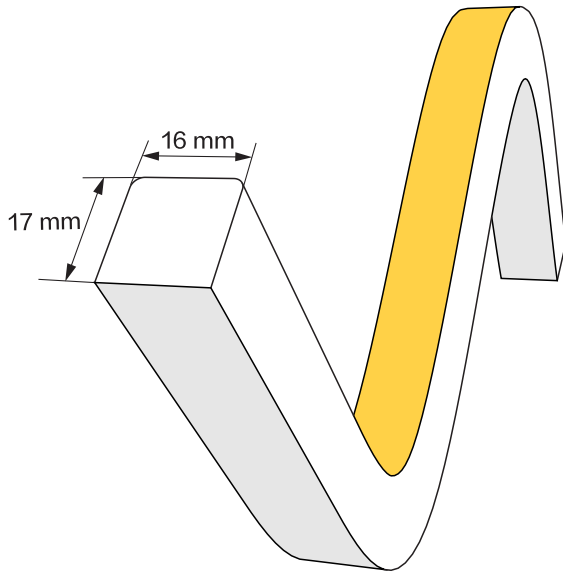

Bend too tight

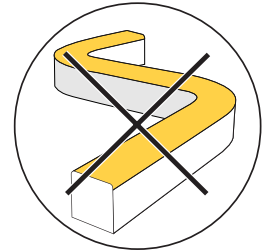
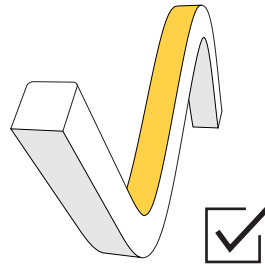

Do not twist



Do not hang

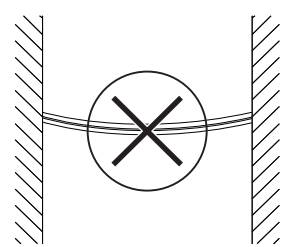

Do not droop

LEDLINE ACE 1617S

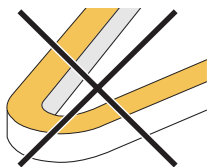
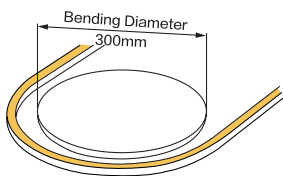
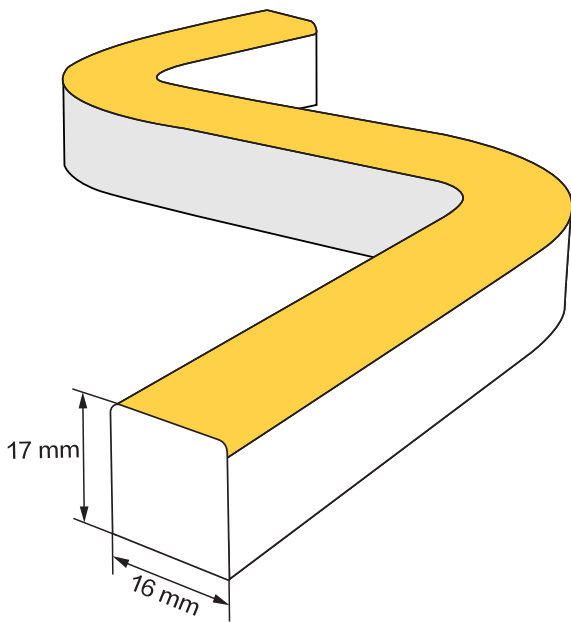

Bend too tight

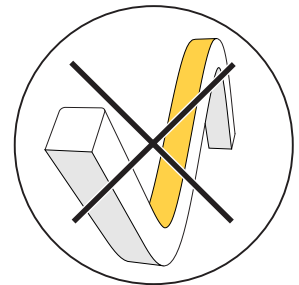
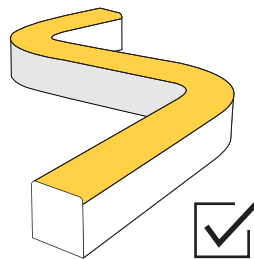

Do not twist



Do not hang

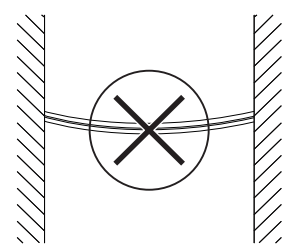

Do not droop

LEDLINE AIR/AXE 1617

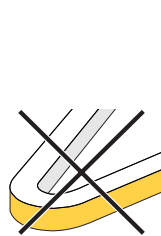
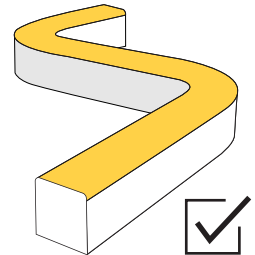
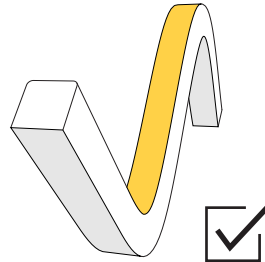
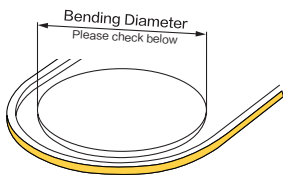
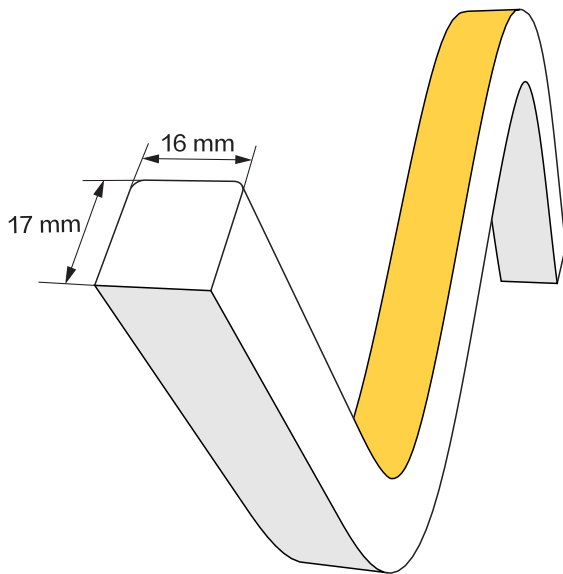

Bend too tight



Do not hang

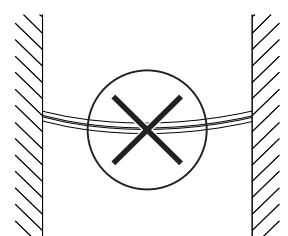

Do not droop

1. The most suitable operation temperature shall be -40°C to 65°C .

2. Please ensure that the predetermined bending direction is maintained throughout installation. Non-3D product can only be bent in one specified direction and must not be twisted.

3. Shall not be bent sharply and it may cause product damage.

4. The minimum bending diameter:
 LEDLINE ACE 1617T : Top bending 300mm
 LEDLINE ACE 1617S : Side bending 300mm
 LEDLINE AIR 1617 (3D): Top bending 200mm; Side bending 200mm
 LEDLINE AXE 1617 DMX (3D): Top bending 200mm; Side bending 200mm

LEDLINE AXE 1617 SL (3D): Top bending 200mm; Side bending 450mm
 over bending will damage and void any warranty.

5. During the installation, the product can not be:
 -Twisted (Non-3D product can not be twisted, 3D product can be twisted within 540°)
 -Dropped
 -Bent at a 90° angle or bent at all
 -Sagging/Hanging down

6. For installation, 2 ways for your selection.
 -Mounting clips
 -Profile

7. Install the product into profile carefully and correctly, taking out and re-assembling will most likely cause the product damaged.

Warranty:

- All LED light are warranted to be free from defects in product itself from the date of purchase.
- Within this period, we, at its sole option, repair or replace any components which fail from correct use. Such repairs or replacement will be made at no charge to the customer for parts only, provided that the customer shall be responsible for transportation cost of the goods.
- This warranty does not cover failures due to abuse, misuse, improper handling, act of nature, negligence, normal wear, accidental damage, modifications or repairs made by the purchaser or incorrect voltage conditions.

Aluminium Profile: AC167-AP

Step1

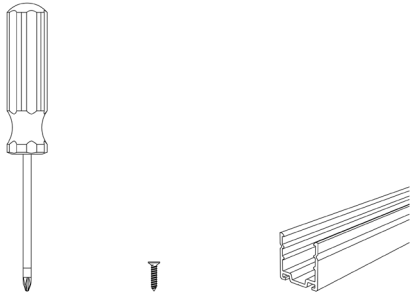

Preparation: Gather all tools and materials.

Step2

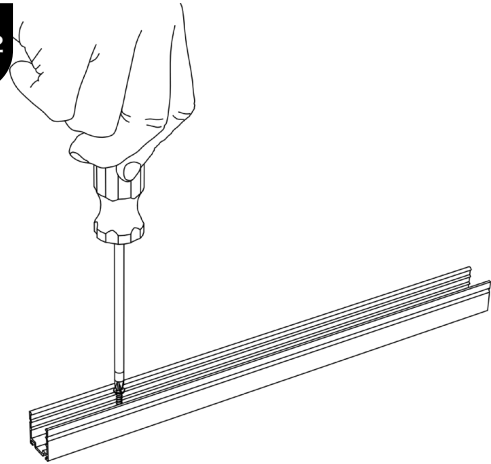

Use screws to secure the profile to the needed installation surface.

Step3

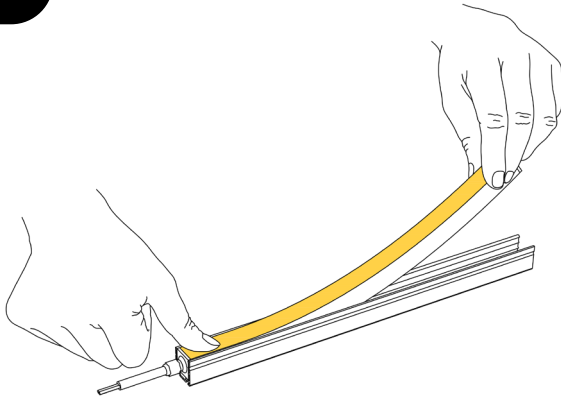

Use your thumb to first fix the starting end of the strip (with wires).

Step4

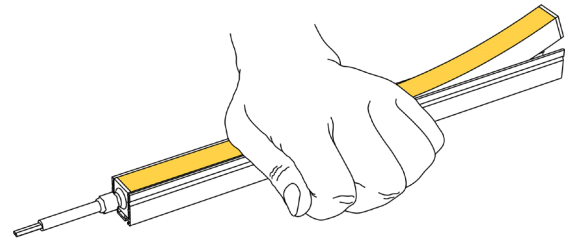

Use your palm to gradually press the Neon strip into the profile.

Step5

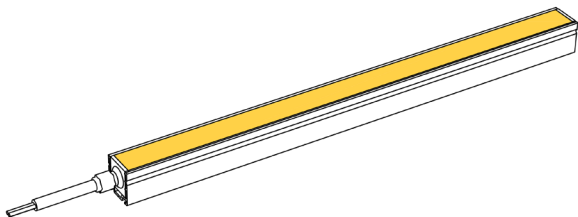

Ensure that the strip is parallel to the profile and installed smoothly in place (as shown in the figure).

Mounting Clips: AC167-MC

Step1

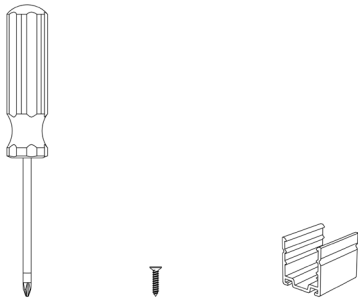

Preparation: Gather all tools and materials.

Step2

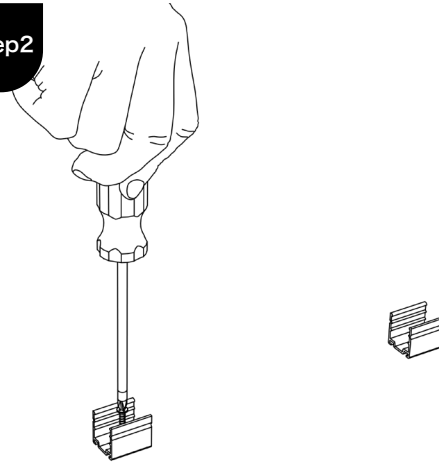

Use screws to secure the profile to the needed installation surface.

Step3

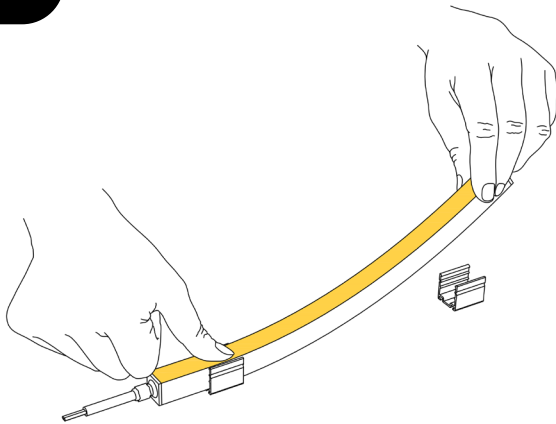

Use your thumb to first fix the starting end of the strip (with wires).

Step4

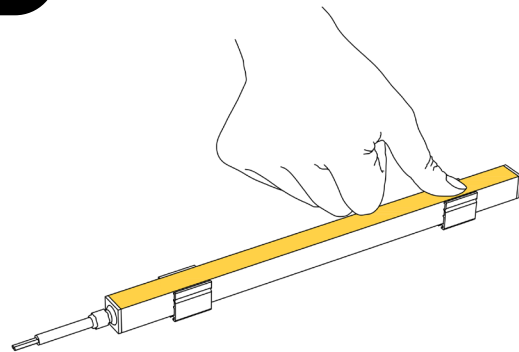

Use your palm to gradually press the Neon strip into the profile.

Step5

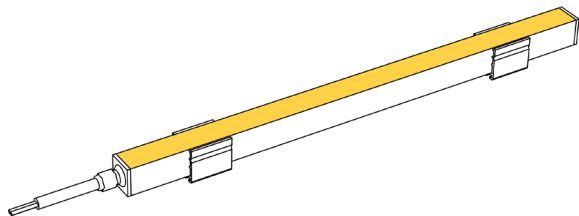

Ensure that the strip is parallel to the profile and installed smoothly in place (as shown in the figure).

PC Profile: AC167-PC

Step1

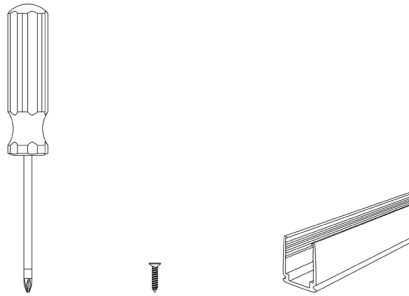

Preparation: Gather all tools and materials.

Step2

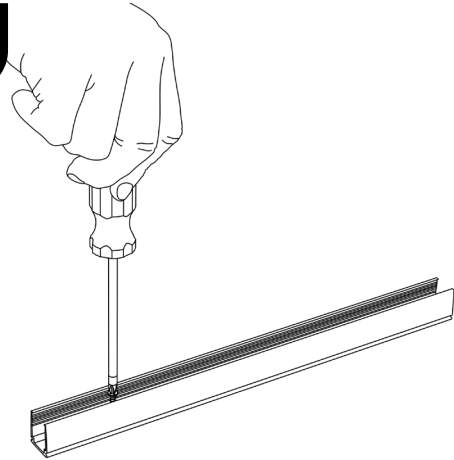

Use screws to secure the profile to the needed installation surface.

Step3

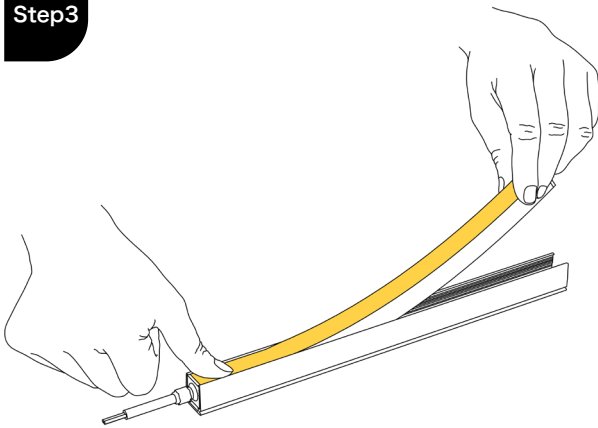

Use your thumb to first fix the starting end of the strip (with wires).

Step4

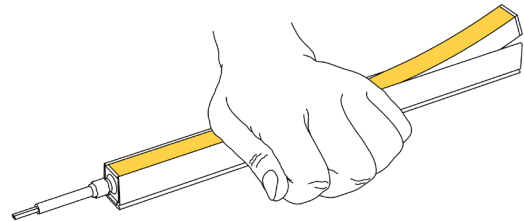

Use your palm to gradually press the Neon strip into the profile.

Step5

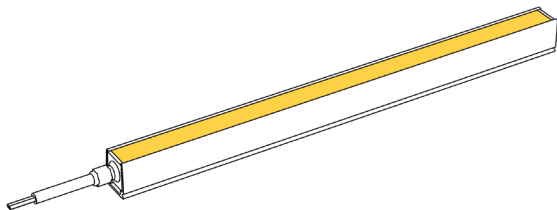

Ensure that the strip is parallel to the profile and installed smoothly in place (as shown in the figure).

Aluminium Profile: AC167-BA

Step1

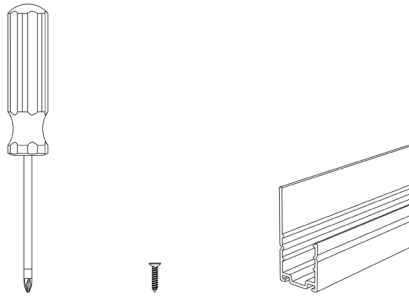

Preparation: Gather all tools and materials.

Step2

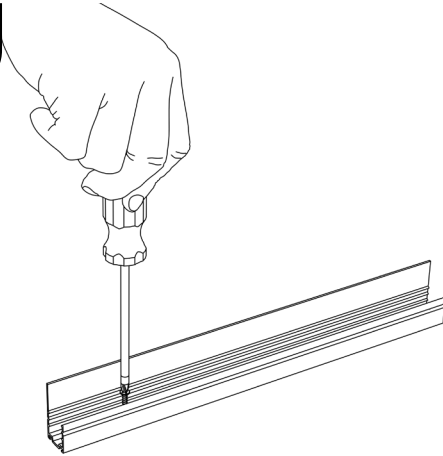

Use screws to secure the profile to the needed installation surface.

Step3

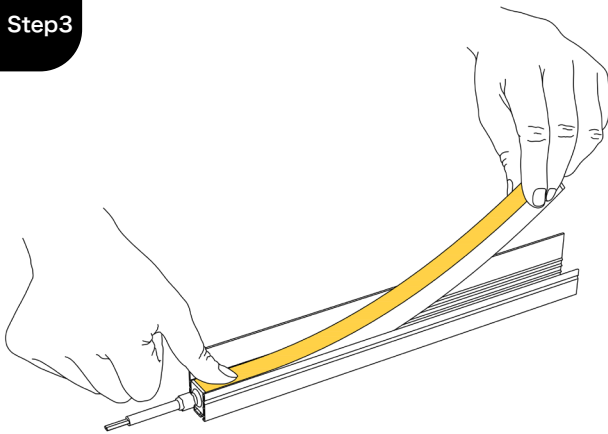

Use your thumb to first fix the starting end of the strip (with wires).

Step4

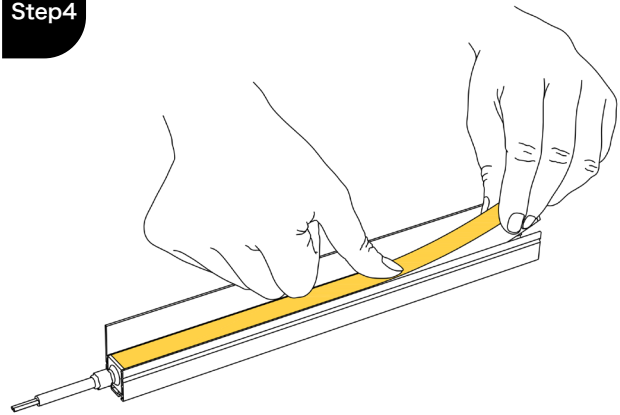

Then gradually press the Neon strip into the profile.

Step5

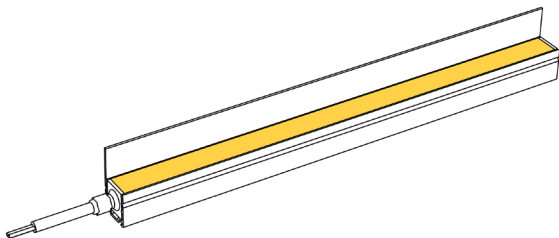

Ensure that the strip is parallel to the profile and installed smoothly in place (as shown in the figure).

Aluminium Profile: AC167-EP

Step1

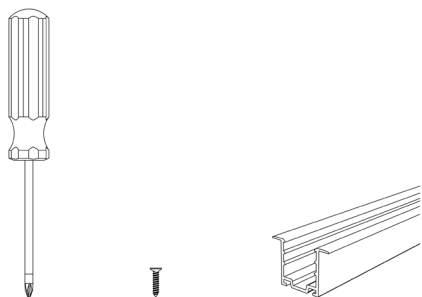

Preparation: Gather all tools and materials.

Step2

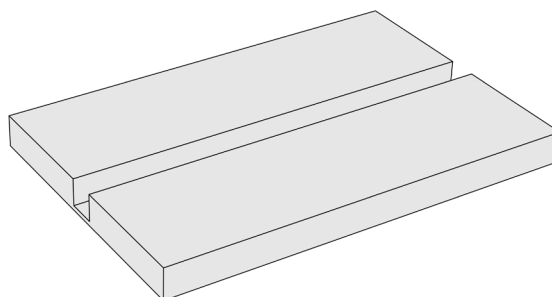

According to the size of the profile, groove the required installation surface (wooden board or wall, etc.).

Step3

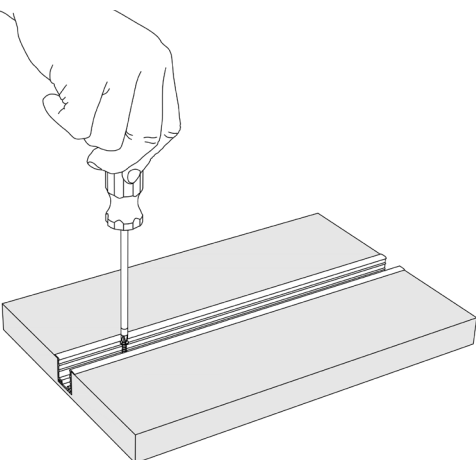

Use screws to secure the profile to the grooved installation surface.

Step4

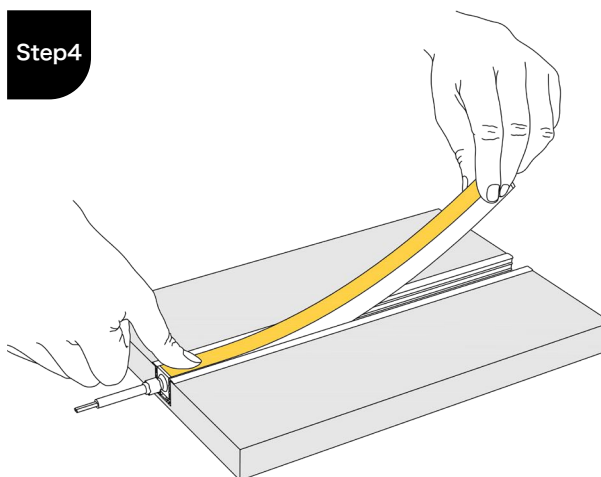

Use your thumb to first fix the starting end of the strip (with wires).

Step5

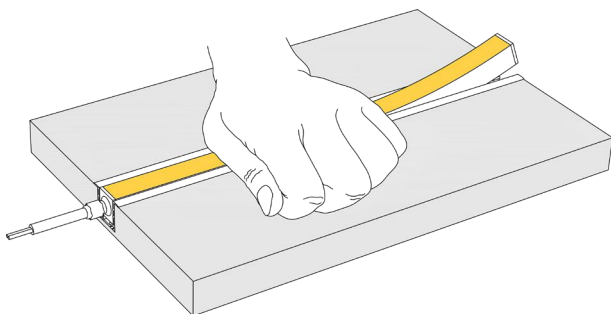

Use your palm to gradually press the Neon strip into the profile.

Step6

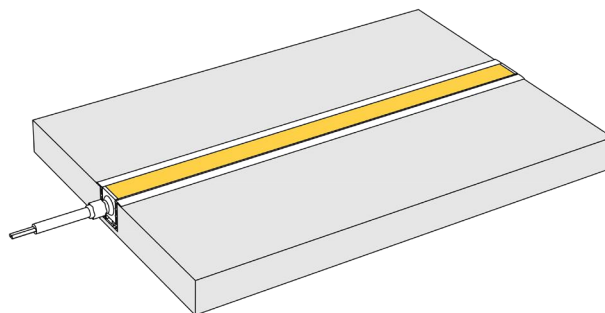

Ensure that the strip is parallel to the profile and installed smoothly in place (as shown in the figure).

PC Profile: AC167-SGP

Step1

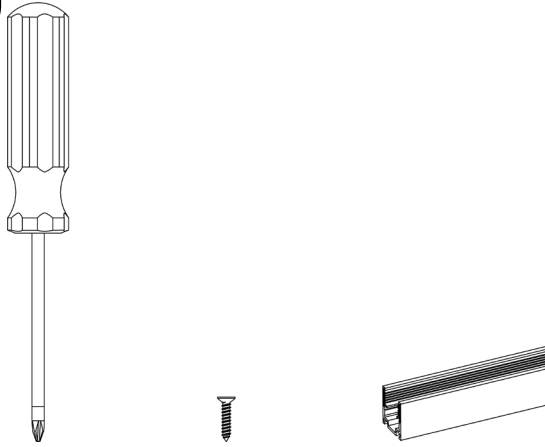

Preparation: Gather all tools and materials.

Step2

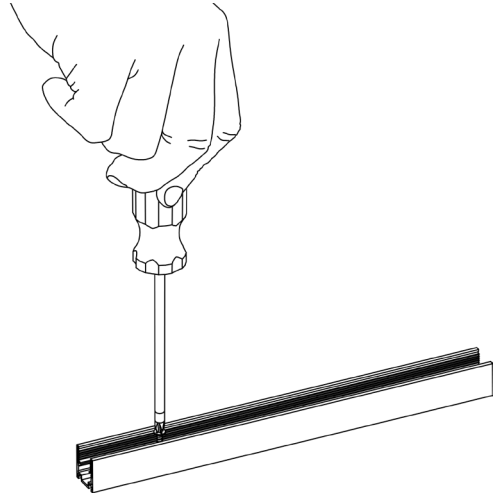

Use screws to secure the profile to the needed installation surface.

Step3

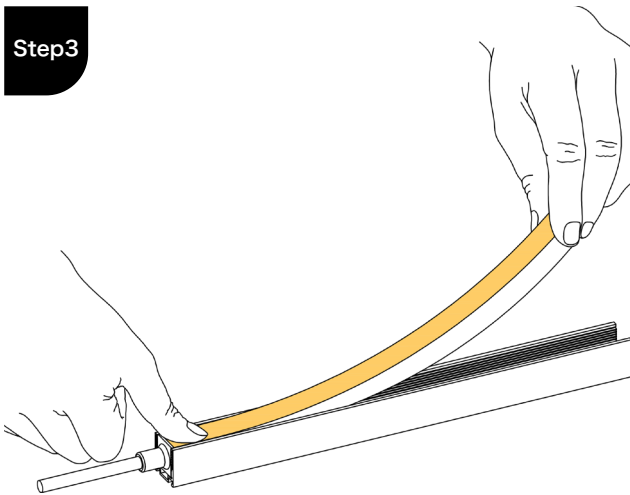

Use your thumb to first fix the starting end of the strip (with wires).

Step4

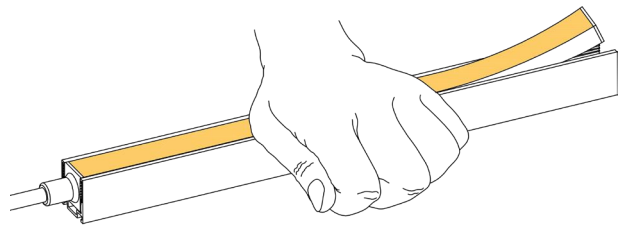

Use your palm to gradually press the Neon strip into the profile.

Step5

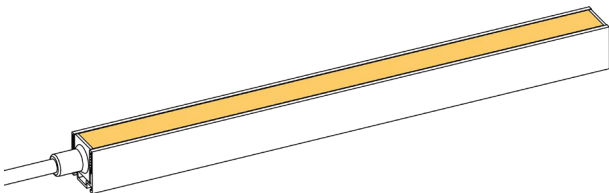

Ensure that the strip is parallel to the profile and installed smoothly in place (as shown in the figure).

Mud-in Application: AC167-LP

Step1

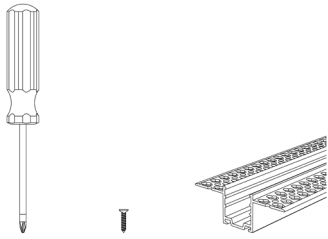

Preparation: Gather all tools and materials.

Step2

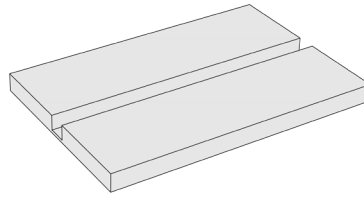

According to the size of the profile, groove the required installation surface (wooden board or wall, etc.).

Step3

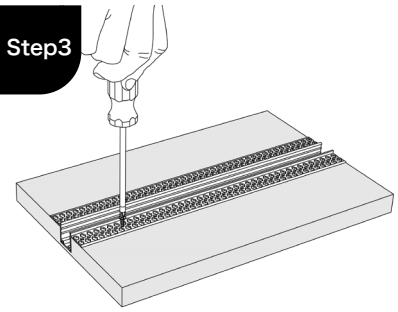

Use screws to secure the profile to the grooved installation surface.

Step4

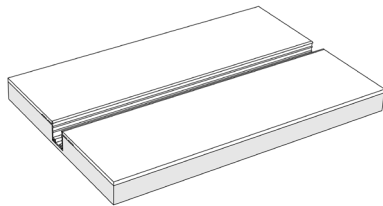

Fix the flange edge of the profile with cement paste (ensure it is level with the installation surface).

Step5

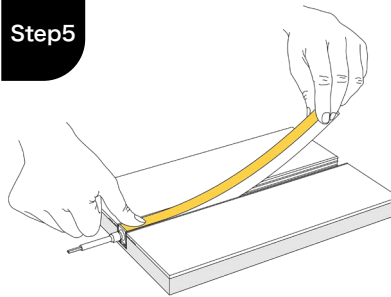

Use your thumb to first fix the starting end of the strip (with wires).

Step6

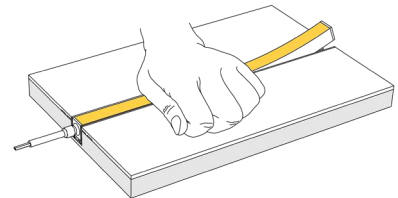

Use your palm to gradually press the Neon strip into the profile.

Step7

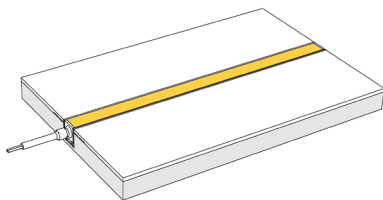

Ensure that the strip is parallel to the profile and installed smoothly in place (as shown in the figure)

Curved Mud-in Application: AC167-CRL

Step1

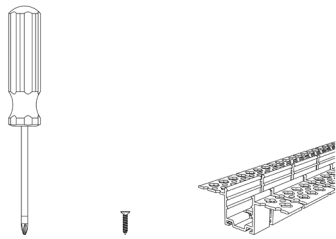

Preparation: Gather all tools and materials.

Step2

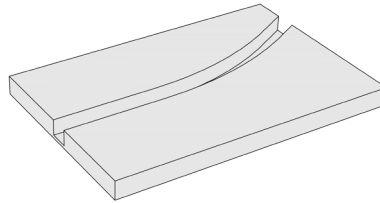

According to the size of the profile, groove the required installation curved surface (wooden board or wall , etc.).

Step3

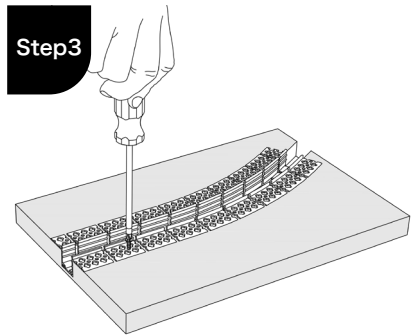

Use screws to secure the profile to the grooved installation surface.

Step4

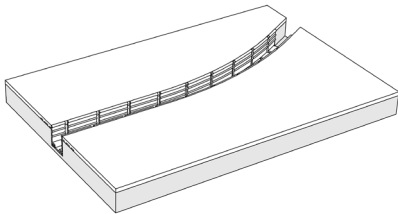

Fix the flange edge of the profile with cement paste (ensure it is level with the installation surface).

Step5

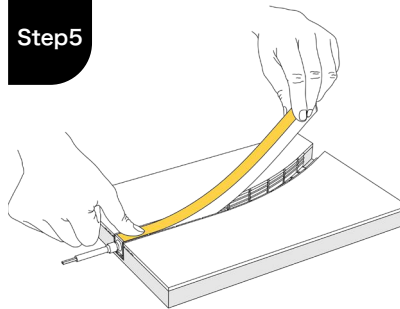

Use your thumb to first fix the starting end of the strip (with wires).

Step6

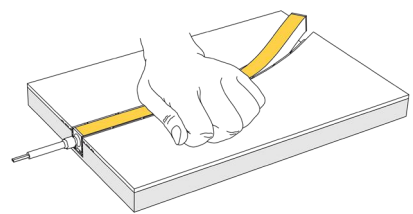

Use your palm to gradually press the Neon strip into the profile.

Step7

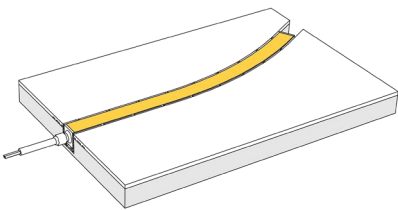

Ensure that the strip is parallel to the profile and installed smoothly in place (as shown in the figure)

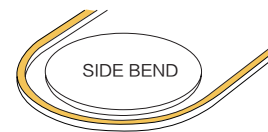
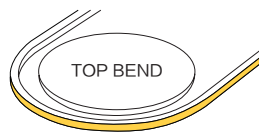

The minimum bending diameter of **AC167-CRL** is 600mm for top bending and 1600mm for side bending

Curved Mud-in Application: AC167-SCRL

Step1

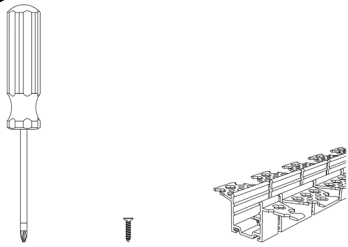

Preparation: Gather all tools and materials.

Step2

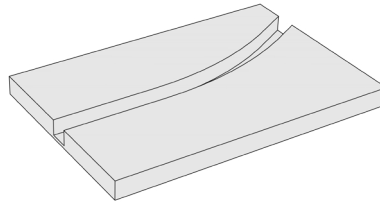

According to the size of the profile, groove the required installation curved surface (wooden board or wall , etc.).

Step3

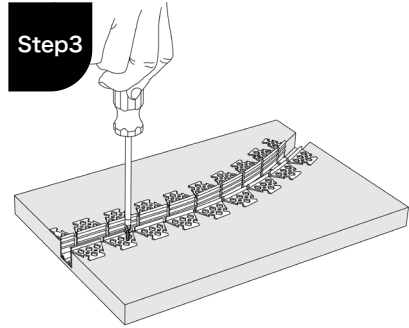

Use screws to secure the profile to the grooved installation surface.

Step4

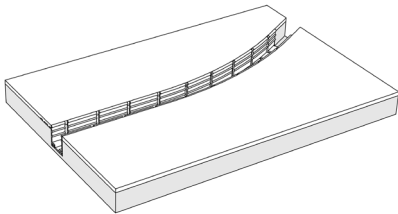

Fix the flange edge of the profile with cement paste (ensure it is level with the installation surface).

Step5

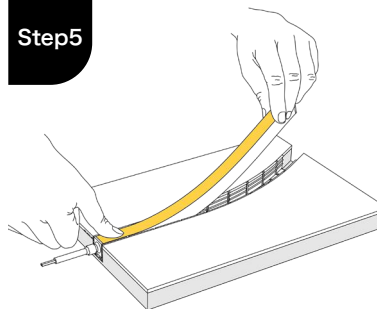

Use your thumb to first fix the starting end of the strip (with wires).

Step6

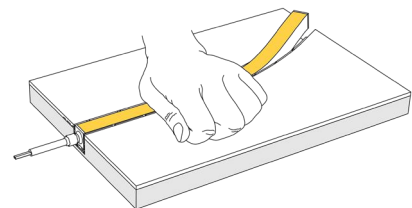

Use your palm to gradually press the Neon strip into the profile.

Step7

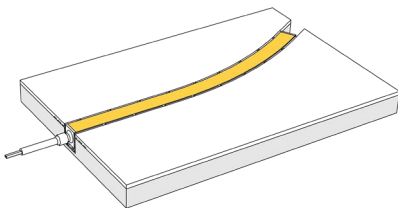

Ensure that the strip is parallel to the profile and in stalled smoothly in place (as shown in the figure)

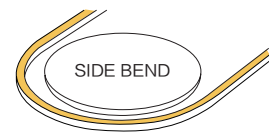
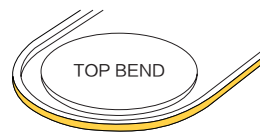

The minimum bending diameter of **AC167-SCRL** is 600mm for top bending and 600mm for side bending;

Aluminium Profile: AC167-CR

Step1

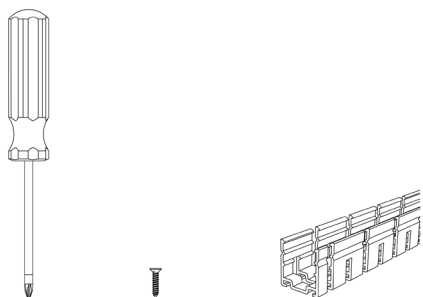

Preparation: Gather all tools and materials.

Step2

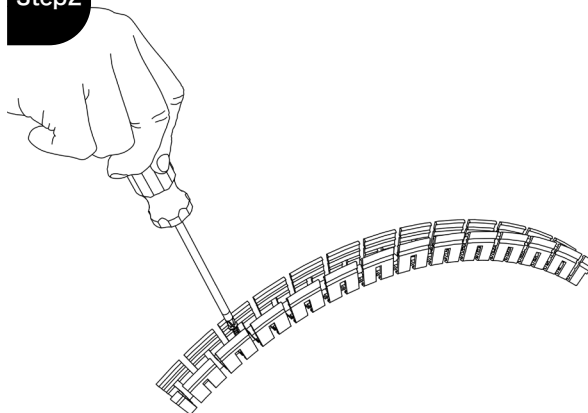

Select the curved installation surface. Bend the profile to fit tightly against the surface and secure it with screws.

Step3

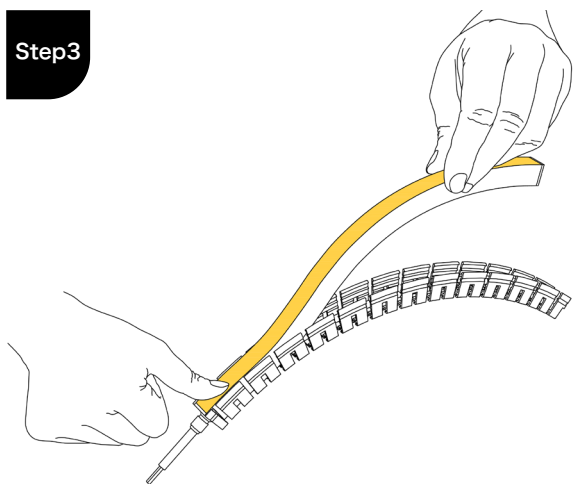

Use your thumb to first fix the starting end of the strip (with wires).

Step4

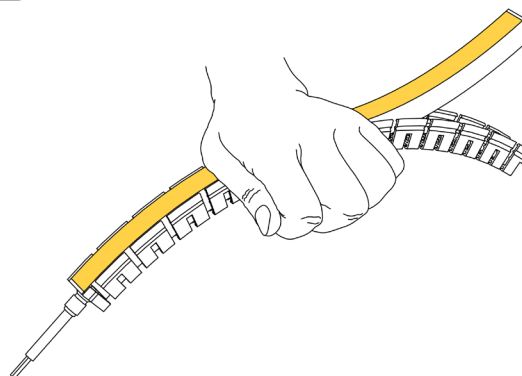

Use your palm to gradually press the Neon strip into the profile.

Step5

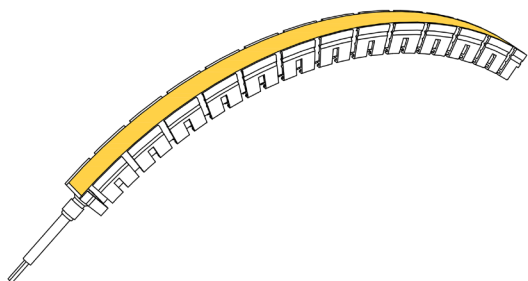

Ensure that the strip is parallel to the profile and installed smoothly in place (as shown in the figure).

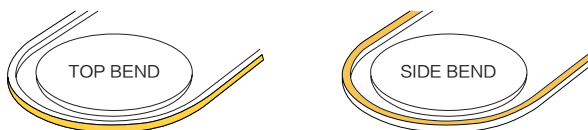

The minimum bending diameter of **AC167-CR** is 600mm for top bending and 600mm for side bending.

PC Profile: AC167-CPC

Step1

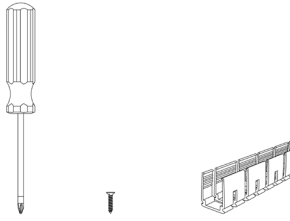

Preparation: Gather all tools and materials.

Step2

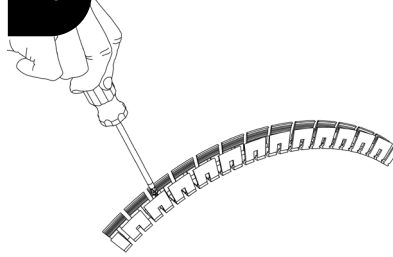

Select the curved installation surface. Bend the profile to fit tightly against the surface and secure it with screws.

Step3

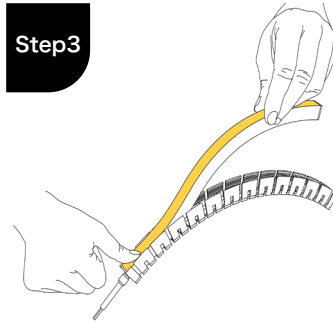

Use your thumb to first fix the starting end of the strip (with wires).

Step4

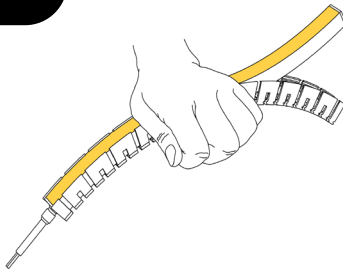

Use your palm to gradually press the Neon strip into the profile.

Step5

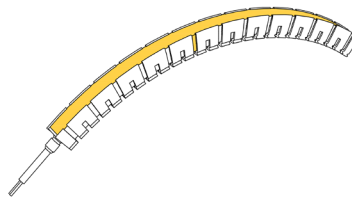

Ensure that the strip is parallel to the profile and installed smoothly in place (as shown in the figure)

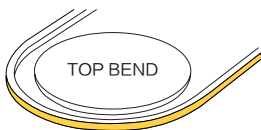

TOP BEND

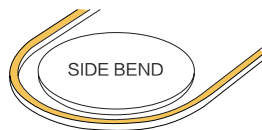

SIDE BEND



The minimum bending diameter of **AC167-CPC** is 300mm for top bending and 300mm for side bending.

PC Profile: AC167-CSGP

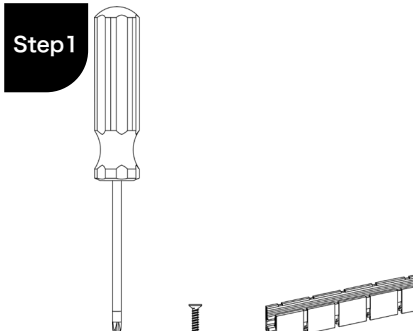

Step1
Preparation: Gather all tools and materials.

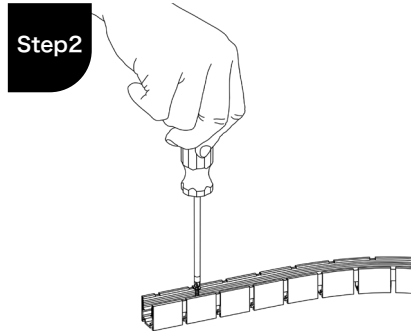

Step2
 Select the curved installation surface. Bend the profile to fit tightly against the surface and secure it with screws.

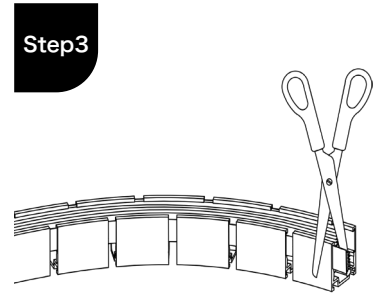

Step3
 After bending the profile, trim off the excess silicone tape on the inside

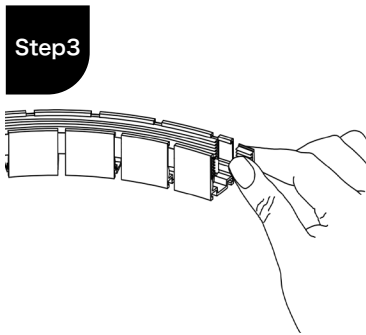

Step3
 Insert the cut silicone tape into the missing section on the outside

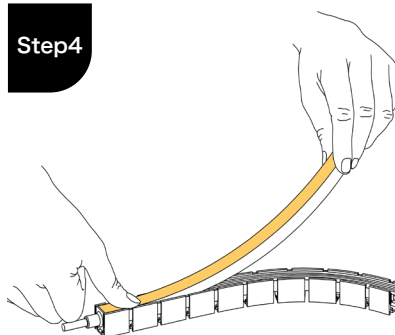

Step4
 Use your thumb to first fix the starting end of the strip (with wires). Then use your palm to gradually press the Neon strip into the profile.

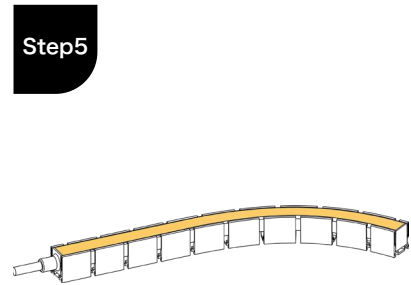

Step5
 Ensure that the strip is parallel to the profile and installed smoothly in place (as shown in the figure)

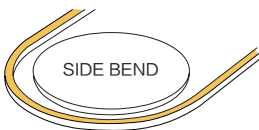

! The minimum bending diameter of **AC167-CSGP** is 600mm for side bending.

!

- 1.The profiles are shipped without holes or screws by default;
- 2.Please pay attention to the bending direction and minimum bending diameter when installing the Neon strip;
- 3.Please have at least two people cooperate during the installation of the Neon strip, one person installing the Neon strip and one person supporting the Neon strip to prevent excessive distortion;
- 4.Please pay attention to the bending direction and minimum bending diameter when installing bendable profiles;
- 5.When removing the Neon strip from the profile, please use screws to slowly lift the Neon strip from the bottom of the profile

Angle Mounting Bracket: AC167-SET-LC

Step1

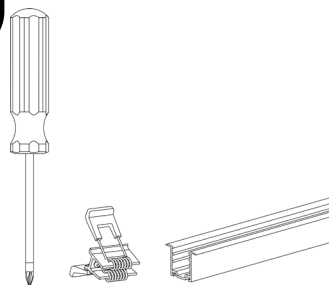

Preparation: Gather all tools and materials.

Step2

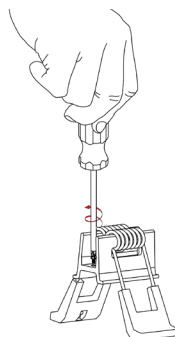

Remove the screw from the clip.

Step3

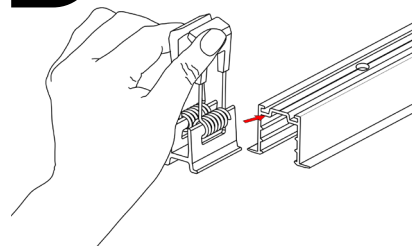

Grip the spring clip and slide into the profile.

Step4

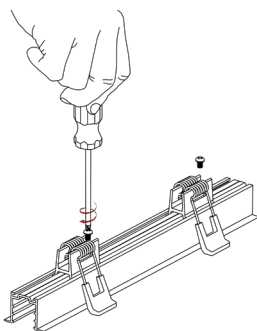

Lock the clip tightly.

Step5

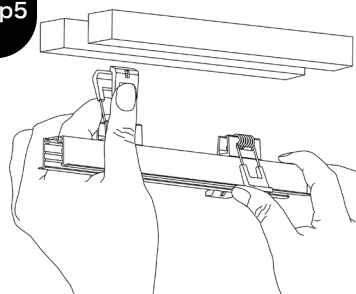

Grip the spring clip and insert the profile into the slot.

Step6

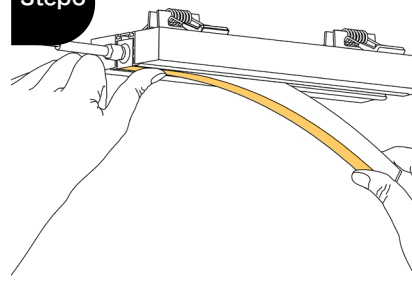

Use your thumb to first fix the starting end of the strip (with wires). Then use your palm to gradually press the Neon strip into the profile.

Step7

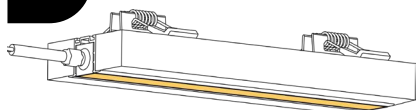

Ensure that the strip is parallel to the profile and installed smoothly in place (as shown in the figure).

AL Shape Mounting Bracket: AC167-SET-LA

Step1

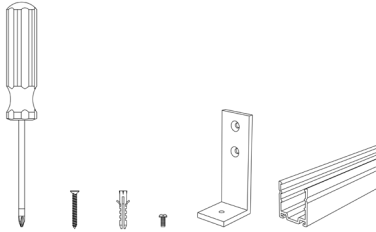

Preparation: Gather all tools and materials.

Step2

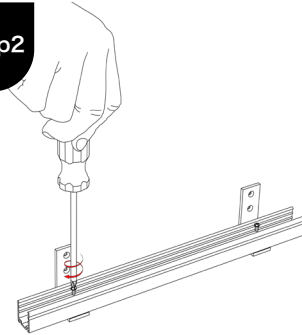

Drill holes in the profile and place it on the short side of the L-shaped bracket. Thread small screws through the holes in the profile and the short side of the L-shaped bracket, tighten them, and ensure they are firmly connected.

Step3

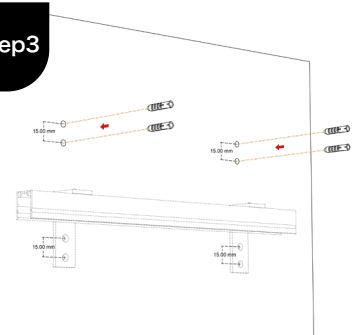

Drill holes on the surface to be installed according to the size of the screws. The distance between the centers of the two screw holes is around 15mm.

Step4

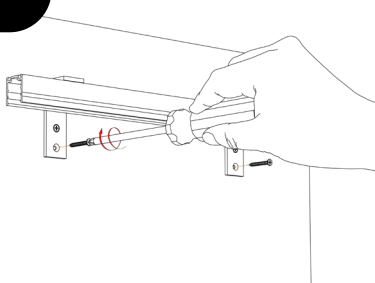

Pick up the fixed profile and bracket, align the two holes on the long side of the L-shaped bracket with the pre drilled holes, and then lock them with long screws.
(Note: first screw in these screws from one left and one right, and then screw in the second screw from one left and one right).

Step5

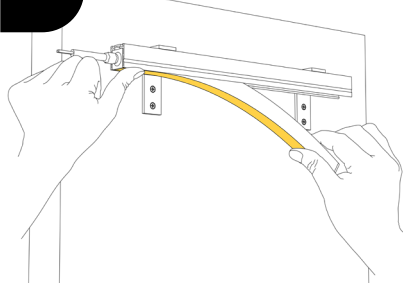

Use your thumb to first fix the starting end of the strip (with wires).

Step6

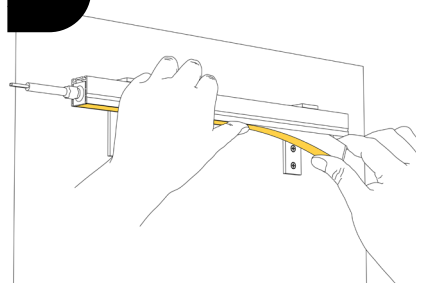

Then gradually press the Neon strip into the profile.

Step7

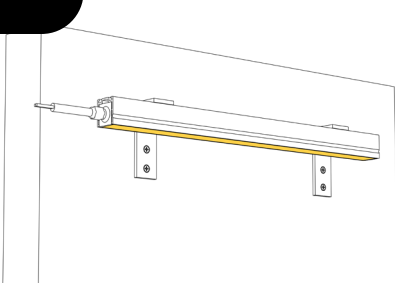

Ensure that the strip is parallel to the profile and installed smoothly in place (as shown in the figure).

Angle Mounting Bracket: AC167-AMB

Step1

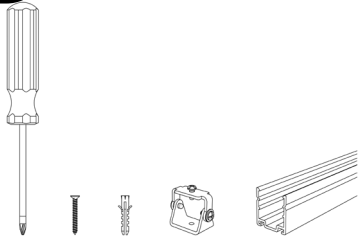

Preparation: Gather all tools and materials.

Step2

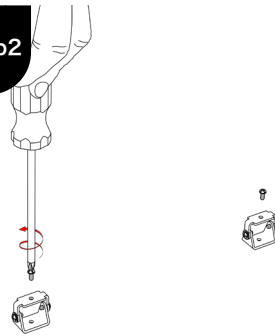

Unscrew all the screws on the rotating bracket.

Step3

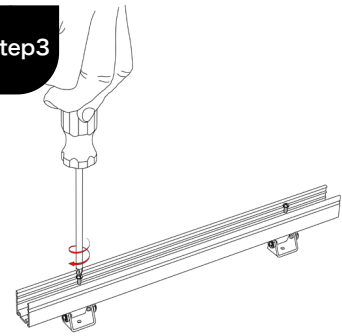

Thread the screws removed from the rotating bracket through the corresponding holes on the profile, tighten them, and ensure that they are securely connected to the rotating bracket.

Step4

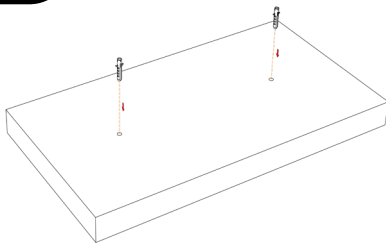

Drill holes on the surface to be installed according to the size of the screws.

Step5

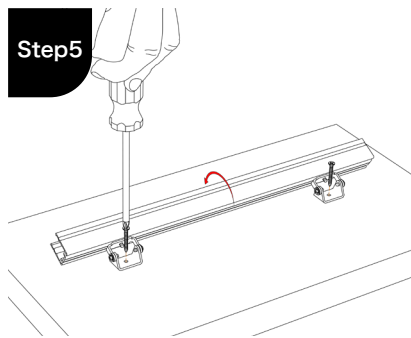

Fix the rotating bracket onto the installation surface with screws.

Step6

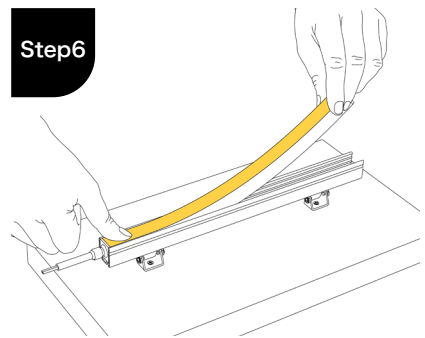

Use your thumb to first fix the starting end of the strip (with wires).

Step7

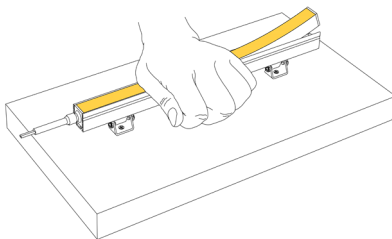

Use your palm to gradually press the Neon strip into the profile.

Step8

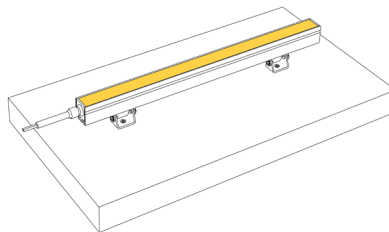

Ensure that the strip is parallel to the profile and installed smoothly in place (as shown in the figure).

Step9

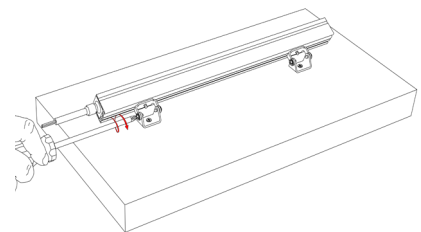

Rotate the rotating bracket to the desired angle, and then use a screwdriver to tighten the screws on the side of the rotating bracket to fix the angle.



JRL INTERNATIONAL LIMITED

Add: Building A, Jingchengda Industrial Park,
ShiyanStreet, Shenzhen, China

W: www.jrlite.com

Tel: +86 755 2160 1337

E: info@jrlite.com